

Schlick Series 631 Series D10.555 Spring-Biased Pressure Nozzles



Applications:

- Cleaning
- Gas/steam flow
- Metering

Schlick spring-biased pressure nozzles

- In the nozzle body a cone-shaped plunger is fitted that closes the orifice under spring pressure.
- The pressure built up by the liquid fed to the nozzle compresses the spring and the plunger is moved forwards, away from the orifice. A gap in the form of a ring appears through which the liquid can discharge. The flow rate is dependent the liquid pressure differential. In addition, the movement of the plunger cone can be limited by a defined stroke and the opening pressure can be varied.
- The spray pattern is shaped like a hollow cone. However, the droplets are very coarse and the liquid distribution is not uniform. These nozzles create more of a coarse widening of the liquid jet rather than a defined spray.
- When the pressure load falls away the plunger closes the ring gap completely again. Clogging of the orifice by external material is therefore impossible.
- These nozzles are highly suited to coarse metering tasks, cleaning and the throughput of gases or steam.

Nozzle designs

Model 631 – Spring-biased pressure nozzle

For flow rates up to approx. 20 l/min at $\Delta p = 3$ bar

Spray angles 45°, 60°, 90°



Fig. 10001

Model 631 K – Spring-biased pressure nozzle

With front end thread for screwing in walls

Spray angles 45°, 60°, 90°



Fig. 10002

Model D10.555 – Spring-biased pressure nozzle

For high flow rates (approx. 50 l/min at $\Delta p = 3$ bar)

Spray angles 45°, 60°, 90°, 120°, 140°



Fig. 10003

Model D10.555 K – Spring-biased pressure nozzle

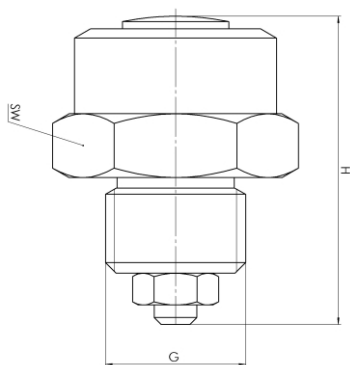
With front end thread for screwing in walls

Spray angles 45°, 60°, 90°, 120°, 140°

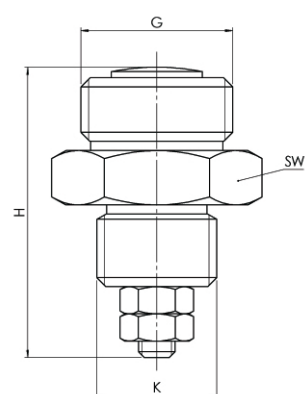


Fig. 10004

Dimensions



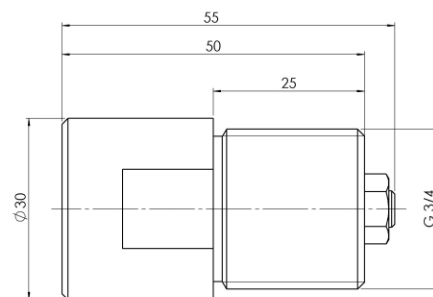
Model 631



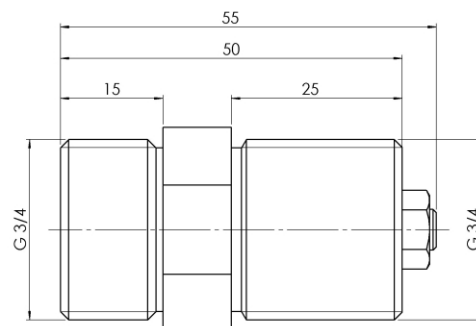
Model 631 K

Model 631	Connector G ISO 228	Front end thread K ISO 228 on Form K	Total height H in mm	Spanner width SW in mm
1	1/4	3/8	~ 29,0	20
2	3/8	3/8	~ 40,0	22
3	1/2	1/2	~ 47,5	27

Model D10.555



Model D10.555 K



Materials

- Acid resistant stainless steel
- Heat resistant stainless steel

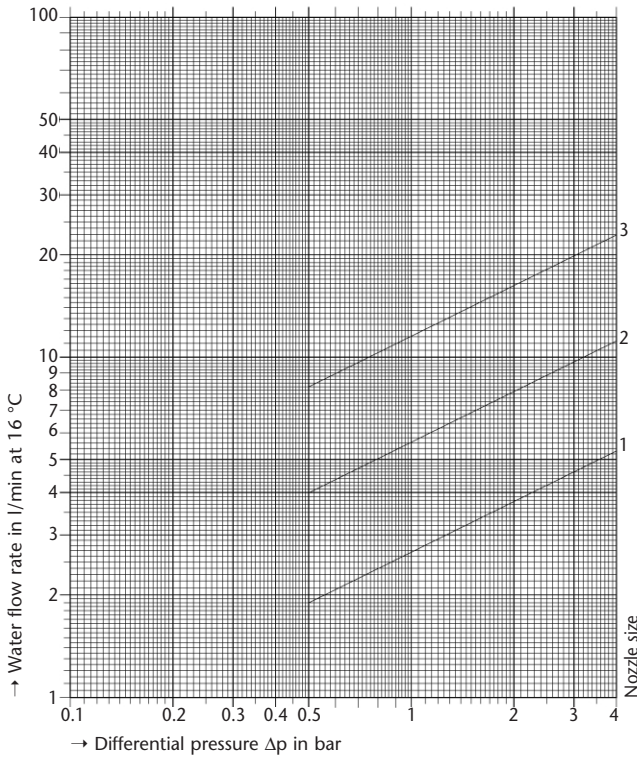
- Brass

Custom products from other materials available on request

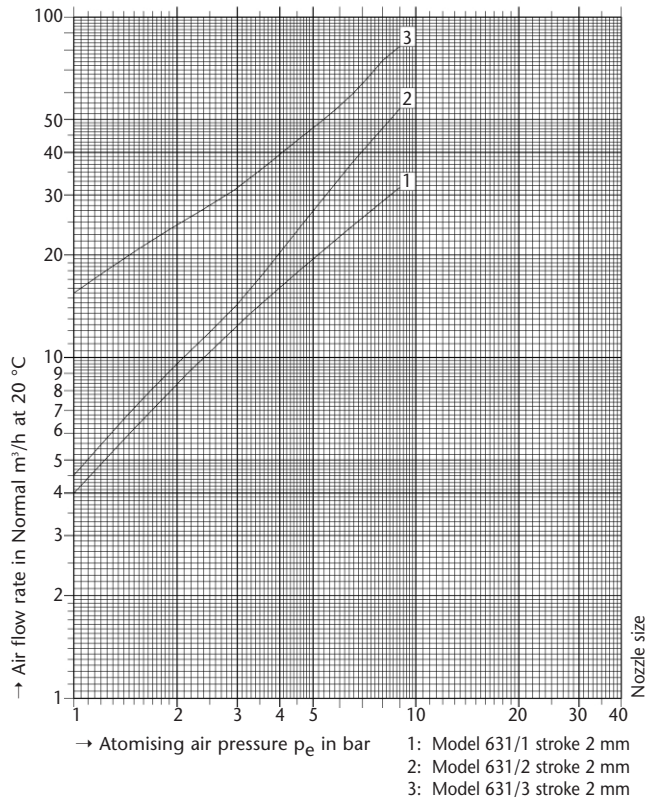
Performance specification

Model 631 – Spring-biased pressure nozzles

Water flow rate in l/min at 16 °C

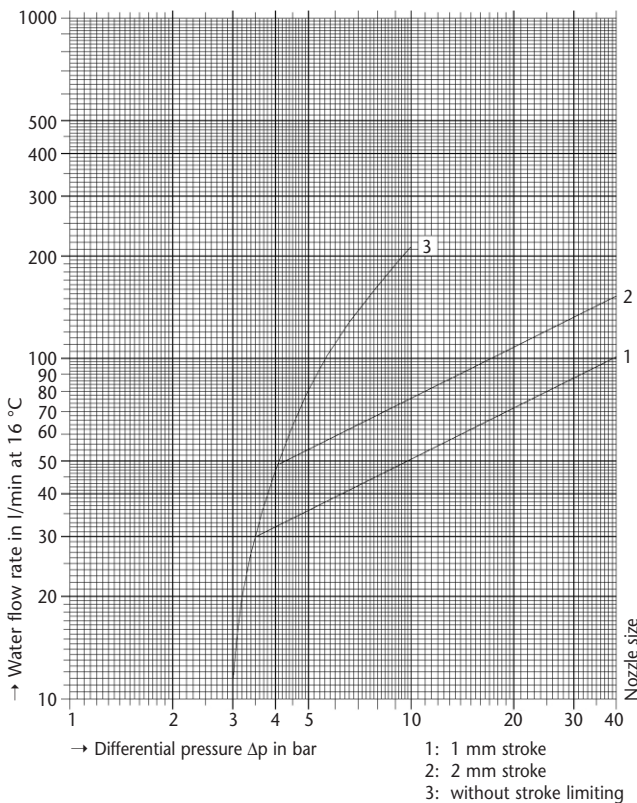


Compressed air flow rate in Normal m³/h at 20 °C

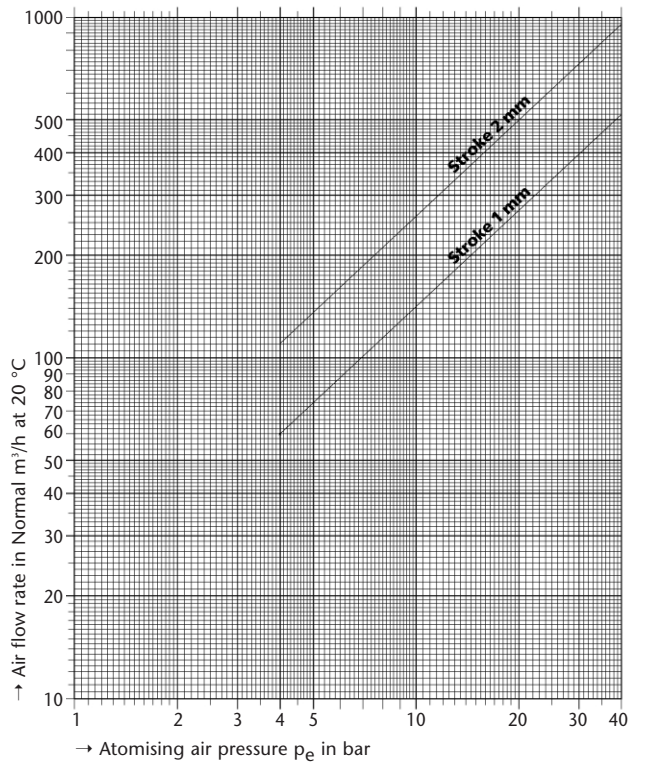


Model D10.555 – Spring-biased pressure nozzles

Water flow rate in l/min at 16 °C



Compressed air flow rate in Normal m³/h at 20 °C



Custom versions

Model D10.555/19 – Spring-biased pressure nozzle

Spray angle 180°, lateral spray



Fig. 10005

Model D10.555/20 – Spring-biased pressure nozzle

For press-fit in a wall



Fig. 10006

Model D10.555/4 – Spring-biased pressure nozzle

Threaded throughout



Fig. 10007

Model D10.555/16 – Spring-biased pressure nozzle

With O-ring groove



Fig. 10008

Service spectrum

Pilot test laboratory

Before any new spray nozzles are used we subject them to comprehensive trials in our own test laboratory – if need be to your operational parameters.

During these tests, we precisely determine droplet size, velocities and flow densities with our modern DUAL PDA laser-measuring equipment.



Test nozzles

Schlick spray nozzles are world renowned for highest precision. We can offer you the best and most lasting solution to your requirements. And, if you want, we can supply you with test nozzles in advance – just contact us.

Engineering

Take advantage of our comprehensive expertise – from design to installation – the conception of new products or

the optimisation of existing plant. We would be glad to help you improve the success of your operation.

Repair service

As well as competent advice and its inception, you can profit from an efficient after-sales service that guarantees long-term supply of all products. We carry out both repair and conversion of Schlick spray nozzles, and in emergency, we can supply spare parts quickly and reliably.

Onsite service

If required we will investigate and develop an optimal solution to suit individual requirements onsite. We will advise you and give you support during installation and initial start-up of the plant. A further plus is the help available from our worldwide technical field service network.

Custom products

As one of the leading spray nozzle manufacturers in Europe, we can offer both high quality standard solutions and are in the position of developing customised products for individual tasks as fast as possible, even for small production runs.



Documentation to the customer's requirements

Reliability and quality are the basis for successful cooperation with our international customers. This applies both to our products and to our service. If you wish, we will supply you with all necessary documentation such as technical handbooks for the nozzles (drawings, flow diagrams, installation and operating instructions) together with factory and material specifications.



All specifications are subject to change (flow rates/dimensions).

The performance/flow rate specifications quoted are descriptive or product identities and can vary by up to ± 5 percent on delivery.



Düsen-Schlick GmbH
Hutstraße 4
96253 Untersiemau
Germany
Tel. +49 95 65 94 81 0
Fax +49 95 65 28 70
info@duesen-schlick.de

www.duesen-schlick.de
www.duesen-schlick.com